

NOTE:

1. DO NOT SCALE DRAWING.
2. DIMENSIONS ARE IN INCHES/(MM).
3. MINIMUM HEADER SIZE 1-3/4" X 4".
4. CUT OUT FOR COVER PLATE 3-3/4" X 15-3/4".
5. CLEARANCE BETWEEN HEADER AND DOOR 1/8".
6. AUXILIARY STOP REQUIRED COINCIDING WITH DEADSTOP ON RTS CLOSER.

FOR 8-32 MACHINE SCREWS USE No.29 (0.136") DRILL DRILL AND TAP THREE (3) HOLES

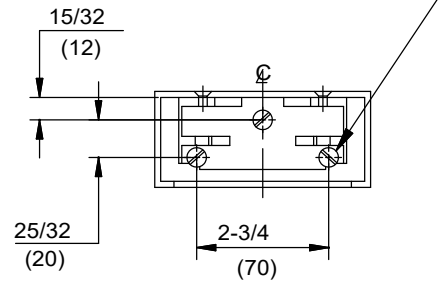

SIDE VIEW
(CLOSER BODY REMOVED)

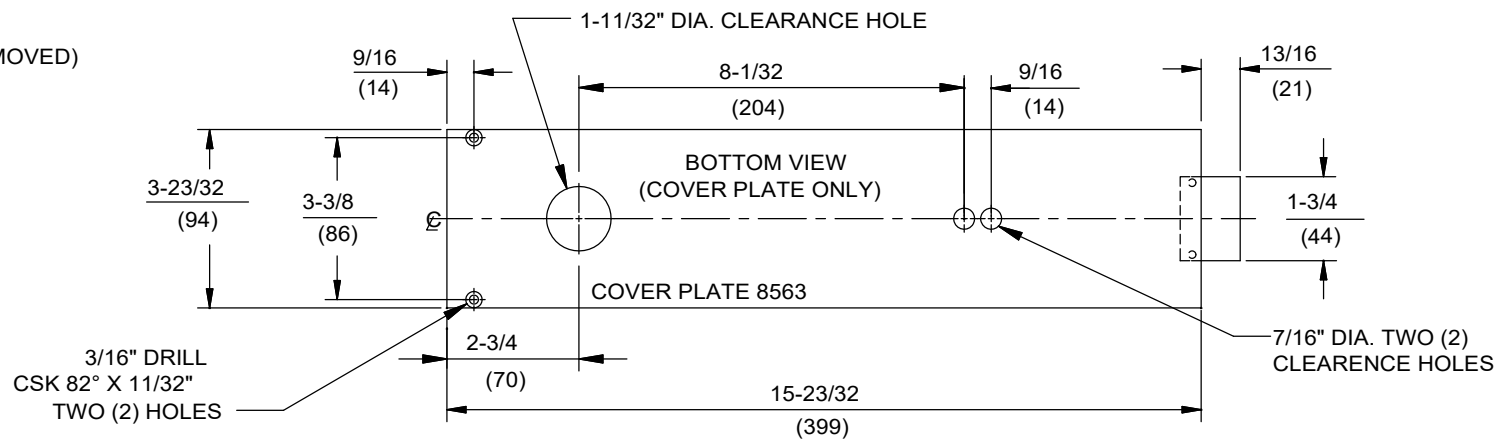
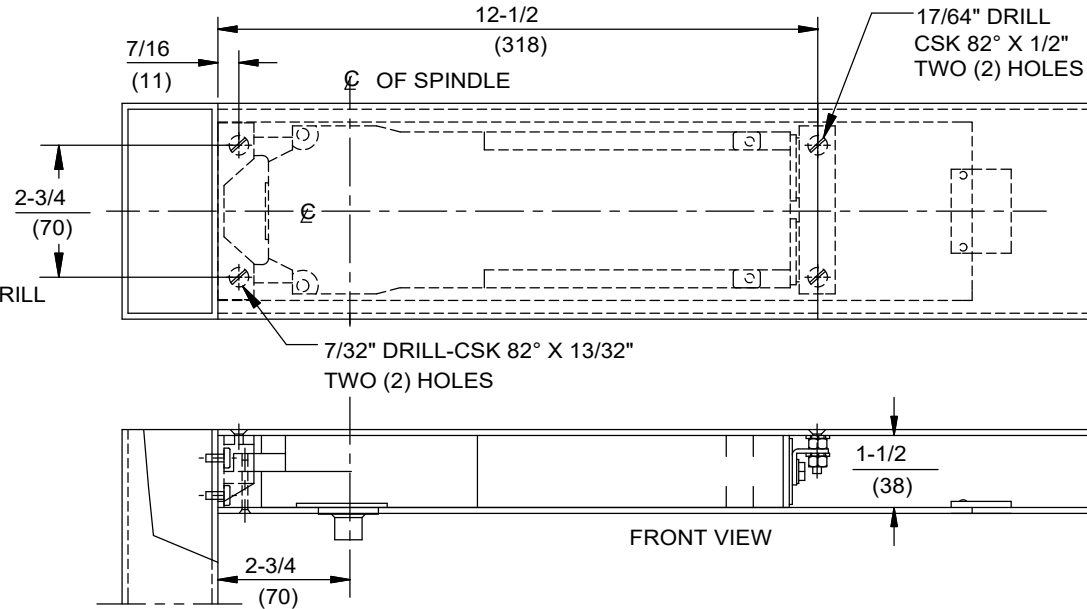

DOOR CLOSER MODEL: RTS SERIES PACKAGE 06, WOOD DOOR AND ALUMINUM
 FRAME PREPARATION, CENTER PIVOTED 2-3/4" BACKSET, No. 8832 SIDE LOAD
 ARM, No. 7421 BOTTOM ARM, No. 7471K FLOOR BEARING,
 No. 8563 COVER PLATE

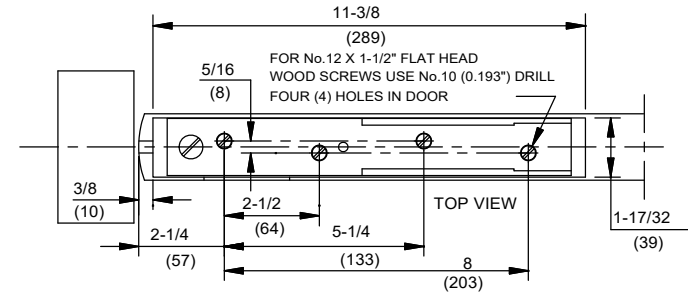
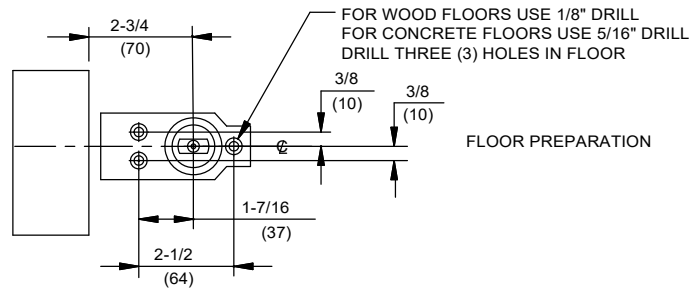

SPINDLE EXTENSION	DOOR CLEARANCE
* STD	3/4-(19)
5mm	15/16-(24.5)
7.5mm	1-(25)
10mm	1-1/8-(29)
15mm	1-5/16-(33)
20mm	1-1/2-(38)
25mm	1-11/16-(43)
30mm	1-15/16-(49)
35mm	2-1/8-(54)
40mm	2-5/16-(59)
45mm	2-1/2-(64)
50mm	2-11/16-(68)

